

Hood Type Dishwasher

■ WD-6 DUPLUS



Wexiödisk 

BECAUSE WE DO CARE



Every installation must result in a good reference!

www.wexiodisk.com

WD-6 DUPLUS

The new generation of dishwasher for small and medium large kitchens.





BECAUSE WE DO CARE

Clean water is essential for life, but one in eight of the world's population does not have access to it. With this aspect in mind Wexiödisk has developed a new dishwashing solution, called DUPLUS. The DUPLUS technology reduces the water consumption to a minimum. Therefore the WD-6 DUPLUS fits perfectly where the lack of water makes it hard to get good or sufficient washing results.



Value adding dishwashing with less impact on the environment

*Wexiödisk is first in the world to introduce the double-final rinse technology for hood dishwashers. Our patent means that the rinsing process uses considerably less fresh water than traditional final rinsing systems. In fact, **only 1 liter of fresh water is used per cycle**, which is remarkably low.*

This low water consumption together with the minimized use of chemicals and electricity makes the WD-6 DUPLUS the perfect choice for a modern kitchen with the environment in mind.



Clean dishes
with clean conscience

every day



WD-6 DUPLUS

- Double final rinse with DUPLUS technology
 - Improved rinsing results using less fresh water
- Optimum wash results
 - thanks to the self-draining wash arms.
- High efficiency with low operating costs
 - DUPLUS technology reduces the consumption of fresh water, chemicals and electricity.
- Particularly large cost savings
 - if osmosis water has to be used.
- A good working environment
 - with the unique hood concept.



Designed for a better working environment

The unique hood concept and the new optional Auto-Start function have improved the ergonomics of the machine and significantly simplified the wash process. Simply slide in the basket, the hood closes automatically and the machine starts. When the wash programme finishes, the hood opens automatically and allows the steam to escape at the back of the machine. The washed items begin to dry immediately and the machine is ready to wash the next basket. It really couldn't be simpler!

If osmosis water is used the financial savings are considerably larger than normal, as osmosis water is expensive to produce.

The WD-6 DUPLUS can be equipped with WEB Tool, an option that simplifies the everyday work with HACCP reports. Using an ordinary Internet browser you create your HACCP documentation directly from the machine.

Only 1 liter of fresh water per cycle!

This is possible thanks to the new patented DUPLUS technology, which minimises the water consumption to almost nothing. The secret is that in the first rinsing phase the WD-6 DUPLUS only uses recirculating rinsing water from the previous washing cycle. In the second rinsing phase the machine uses fresh-water at a temperature of 85-90°C. The rinse water from the second phase is collected to be used for the next washing cycle.

The new innovative DUPLUS technology saves water, chemicals and electricity in the dishwashing room and makes it the best choice for a modern and professional kitchen.



Easy access easy cleaning

The unique design of the basket conveyor makes it possible to lock it in an upright position for easy access to the strainer and easy cleaning.

In order to allow any faults to be resolved quickly and efficiently the machine has an event log which records all the alarms and any changes made to the machine. This helps to ensure rapid troubleshooting and improved diagnostics. As in all Wexiödisk machines, the components are carefully positioned to allow easy access for servicing from the front of the machine.



1



2

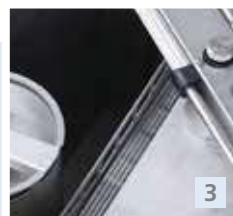

3



4

1. Effective strainers and the design of the basket conveyor helps to improve the washing results even further by ensuring that the water jets can easily reach every corner of the basket. Smooth internal surfaces make cleaning easier.

2. The concave design of the nozzles on the washing arms prevents them from being blocked. To improve the quality of the final rinse and the hygiene levels, the washing water drains out of the washing arms at the start of the rinse phase. This prevents any residual washing water from dripping out of the top washing arm onto the clean items.

3. The rinse water collector is specially designed to collect a maximum of water during each final rinse. The water is then reused for the recirculated rinse.

4. On the front of the machine there is an anti-clogging filter to prevent the recirculated final rinse nozzles being blocked.

■ The unbeatable washing system for the modern kitchen with high demands on efficiency

Forget the extra manual work involved and the additional use, or rather waste, of clean water with the WD-PRM6. No longer will you need an overhead spray unit to pre-rinse soiled dishware. By combining the optional automatic hood with Auto-start you simply push your dish rack into the pre-rinse unit. The hood will close and begin the cycle. After 30 seconds and 200 liters of recycled pre-rinse water the hood opens automatically and the rack can be moved into the main dishwasher. And, for versatility, if your soil load is light, the PRM can simply be by-passed. It does not operate if a rack is not detected in the chamber.



CASE STUDY

Assuming you wash 150 racks per day, then each year:

- you save around 200,000 litres of water.
- you save 8000 kWh energy when using warm or hot water.
- you save the environment from 4100 kg CO₂
- you save 85 hours of labour.
- Spare your staff from 55000 repetitive manual pre-rinsing movements.
- you use less detergent.
- your work environment is improved with less water splashing.
- you achieve a higher capacity out of a single tank machine.
- you reduce the need of water changes during the day.

Replace the manual pre-rinse with WD-PRM6

Save money,
time and your
staff.

Major water savings using overflow water

The PRM Green washes for 30 seconds with 200 liters of hot recycled detergent water, both from above as well as underneath, which is impossible to achieve manually. There is significant water saving by using overflow water from the dishwasher in the pre-rinse unit. Not only does the PRM give 20 times better result than traditional overhead spray units, it also reduces the running cost by totally eliminating manual pre-rinsing. In this way operators can focus on sorting and arranging dirty dishes more efficiently.

Improved working environment

By using the PRM the total contact time is extended. This increases the total capacity for the hood type machine since shorter washing programs can be used. The working environment is improved by replacing the repetitive manual pre-rinsing movement that can lead to occupational injuries. Additionally, your working environment is improved by less water splashing.

Today most people focus on final rinse water consumption, not taking into consideration the huge amount of both fresh water consumed by manual pre washing and energy going into the drain every day.

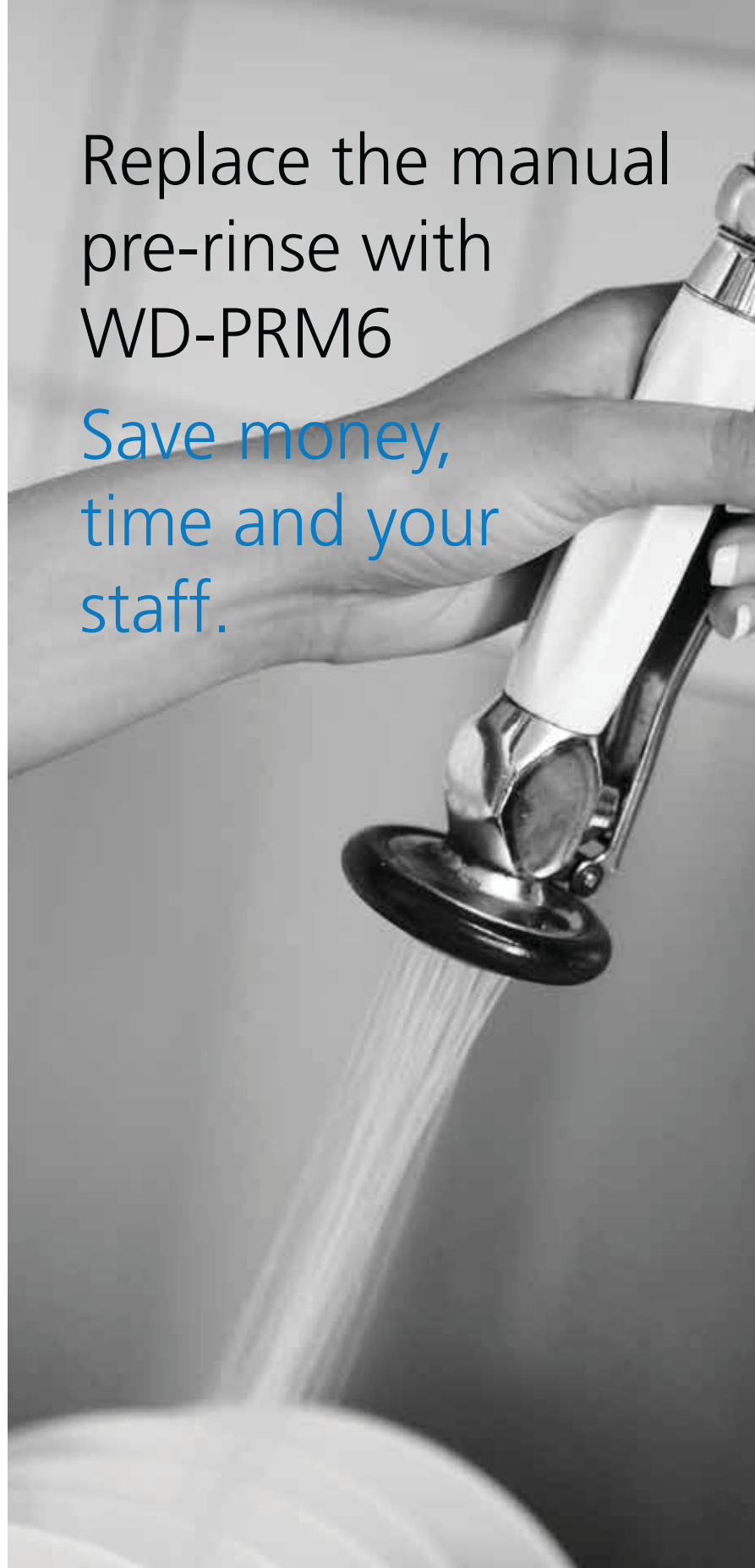

Technical data WD-6 DUPLUS

Technical data	WD-6 DUPLUS
Wash pump (kW)	0,9
Pump, recirculated rinse (kW)	0,46
Pump, final rinse (kW)	0,46
Booster heater (kW)	9
Tank heater (kW)	5,4
Tank volume, chemical wash tank (liter)	45
Tank volume, final rinse tank (liter)	5,5
Weight, machine in operation (kg)	185
Enclosure class (IP)	45

Capacity and operating data	WD-6 DUPLUS
Total washing time P1 (min) *	1.2
Total washing time P2 (min) *	1.8
Total washing time P3 (min) *	3.3
Max. capacity, baskets/hour (no.)	50
Water consumption rinsing/programme (liter) **	1.0 - 1.5
Energy consumption (% of connected power)	30 - 50%
Sound level (dB(A))***	63

* Factory setting. The washing time can be adjusted.

** In combination with WD-PRM6 the water consumption can be lowered further.

*** Measured 1 metre from the side of the machine.

Connection, machine	WD-6 DUPLUS
Total connected power (kW)	9.9
Main fuse 400 3N~ (A) *	16
Max. connection area 400-415V 3N~ (L1-L3,N,PE) Cu (mm ²) **	2.5

* Other voltage on request.

** Cable 3 m H07RN-F is included.

Water, drain and ventilation connections	WD-6 DUPLUS
Water quality, hardness (°dH)	2 - 7
Water connection 5-70°C (external thread) *	R 1/2"
Drain connection, PP pipe (ø mm.)	50
Water capacity, min/max pressure (kPa)	1/500
Water capacity, flow (litres/min)	10
Floor drain, capacity (litres/sec)	3
Heat load to the room (total, sensible, latent) (kW)	1,7 / 1,2 / 0,5

* When using cold water <55°C the filling time is longer.

Size and weight for transportation	WD-6 DUPLUS
Size, LxWxH (mm.)*	765x710x1560
Weight (kg)*	140

* Packaging included

Additional equipment

Machine model	Part.no	Dimensions in mm DxWxH	Booster heater	Electrical connection
WD-6 DUPLUS	203-06D...	657x600x1430/1875	9 kW	400V 3N~ 50Hz 9,9 kW 16A
Options				
Automatic hood				
Autostart for automatic hood				
Marine version 400V/3/50Hz without zero				
Marine version 440V/3/60Hz without zero				
Detergent dispenser for liquid detergent				
Drain pump				
WEB Tool				
Additional equipment				
Condensing unit with heat recovery by the exhausted steam.* Only in combination with automatic hood. The dishwasher is connected to cold water	203-0640			
Steam hood with suction connection ø 160 mm	203-0630			
Right-hand side shelf for chemical storage	203-0663			
Left-hand side shelf for chemical storage	203-0664			

* Data about the heat recovery systems, see separate brochure.

WD-6 DUPLUS and WD-PRM6



WD-6 DUPLUS combined with pre-rinse machine WD-PRM6 gives the best possible hygiene, washing result and efficiency in the kitchen. The system saves not only water but also electricity and chemicals ... and your staff.

Dimensional drawings WD-6 DUPLUS

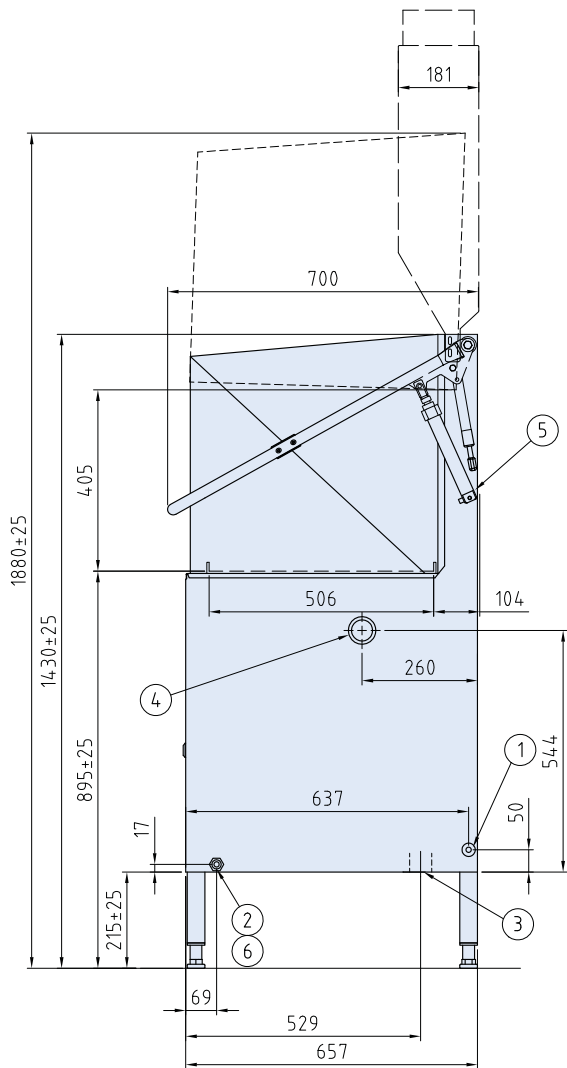

Steam hood
(option)

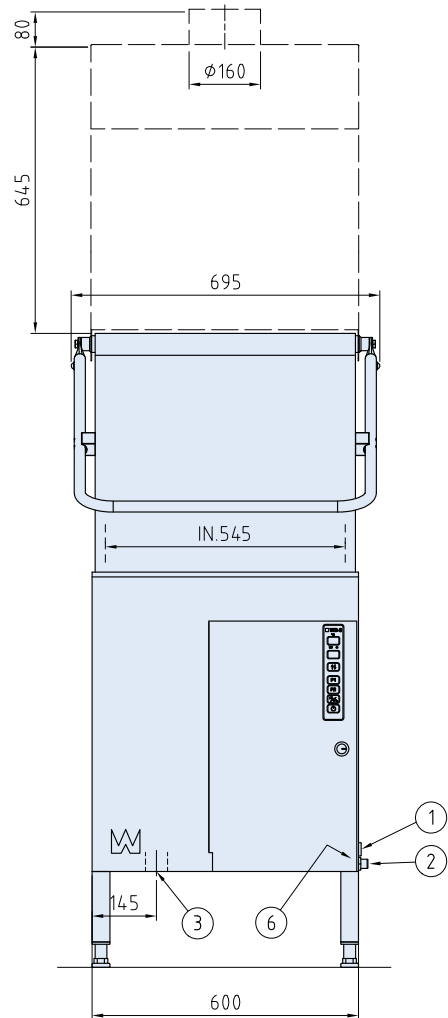

1. Electrical connection
2. Water connection R $\frac{1}{2}$ "
3. Drain connection, diameter 50 mm, 3l/sec
4. Plugged hole for detergent hose
5. Bleed screw for the lifting cylinder
6. Water outlet for detergent

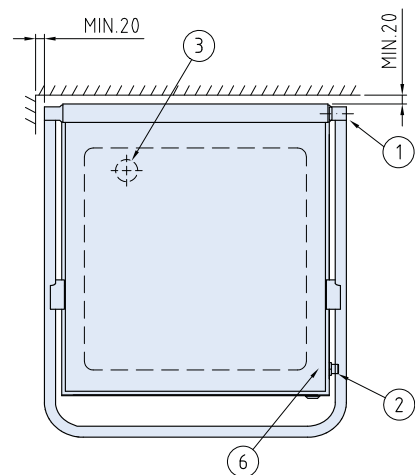

■ Connection

Straight feed

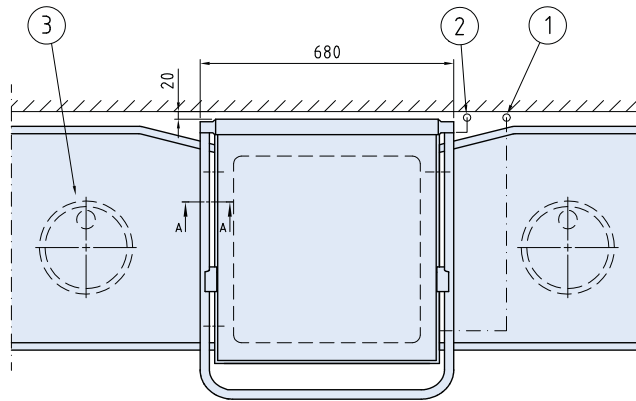

1. Water connection
2. Electrical connection
3. Floor drain. Capacity 3l/sec
4. Legs. Must be placed a minimum of 300 mm in front of the machine

Corner feed

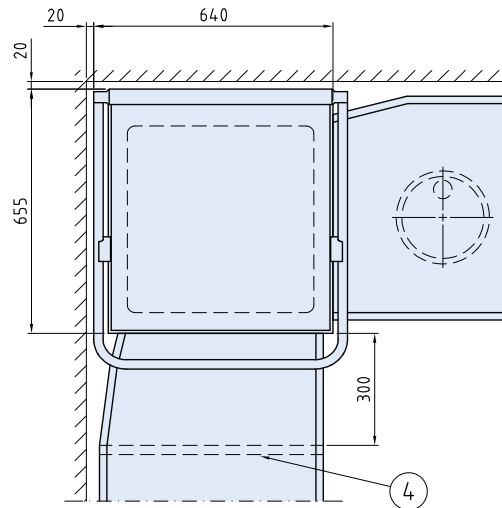

Sink connection

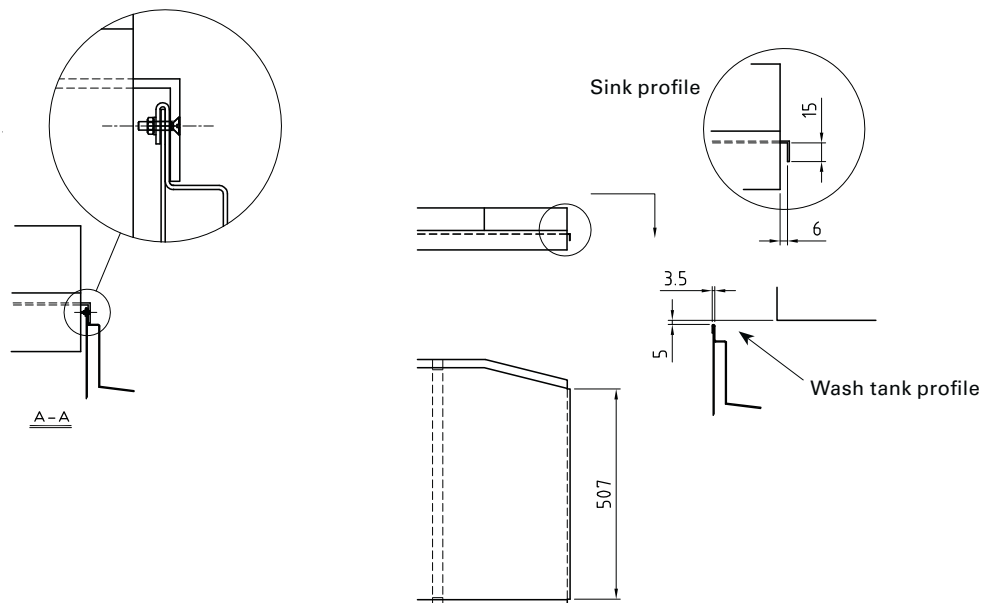

■ Technical data WD-PRM6

Technical data	WD-PRM6
Article number	204-006
Wash pump (kW)	0,9
Tank volume (litres)	45
Weight, machine in operation (kg)	130
Degree of protection (IP)	45
Capacity and operation data	WD-PRM6
Total time pre-rinse (min)	0,5
Capacity, max (baskets/h)	120
Sound level* (dB(A))	64
Connection, machine	WD-PRM6
Total connected power (kW)	0,9
Main fuse 400V 3N~(A)**	10
Max.conn.area 400V 3N~ (L1-L3,N,PE) Cu (mm ²)***	2,5
Connection water, drain and ventilation	WD-PRM6
Drain connection, PP pipe (ø mm)	50
Water capacity cold water hood lift, pressure (kPa)****	300
Water capacity cold water hood lift, flow (l/min)****	2
Floor drain, capacity (litres/sec)	3
Heat load to the room (total, sensible, latent) (kW)	0,3 / 0,2 / 0,1
Size and weight for transportation	WD-PRM6
Size ***** LxWxH (mm)	765x710x1560
Weight ***** (kg)	100
Extra equipment	WD-PRM6
Connection kit with splash guard between PRM and WD-6/WD-7, connection plate L= 140 mm. (Not for connection to the front of the dishwasher.) For straight installation.	204,0660
Connection kit without splash guard between PRM and WD-6/WD-7, connection plate L= 300 mm. (For corner installation.)	204,0665
Connection kit with splash guard between PRM and WD-6/WD-7, connection plate L= 300 mm. (Not for connection to the front of the dishwasher) For straight installation.	204,0666
Connection kit with splash guard with cabinet for chemicals, between PRM and WD-6/WD-7, connection plate L= 300 mm. (Not for connection to the front of the dishwasher.) For straight installation.	204,0668

* Measured 1 metre from the machine

** Other voltages on request

*** Cabel 2m H07RN-F included

**** Option. If pressure / flow is lower the machine should be equipped with a booster pump.

***** Packaging included

The total amount of saved water, energy and labour depends on local conditions.

■ Dimensional drawings WD-PRM6

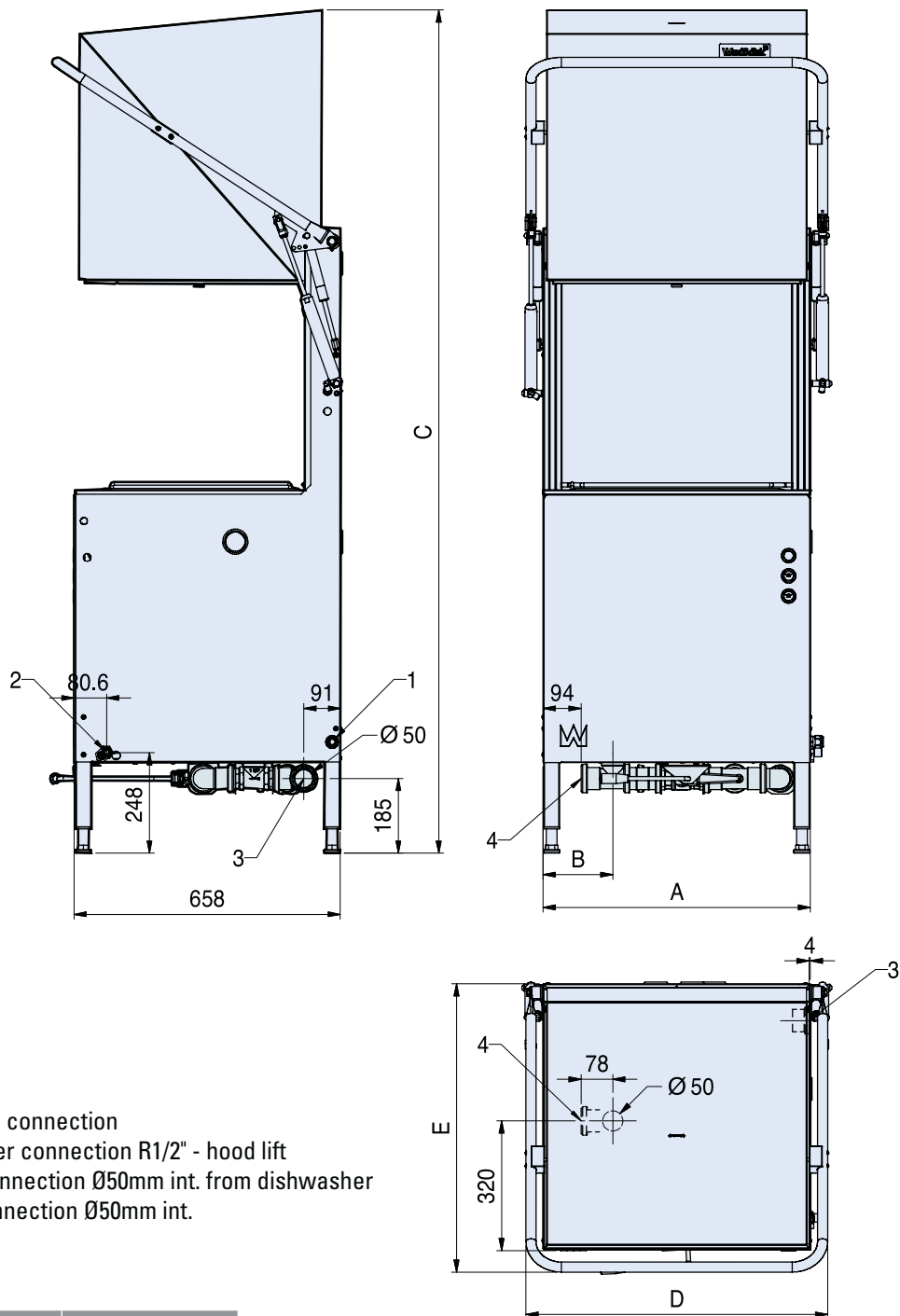

1. Electrical connection
2. Cold water connection R1/2" - hood lift
3. Water connection Ø50mm int. from dishwasher
4. Drain connection Ø50mm int.

DIM mm	WD-PRM6
A	600
B	142
C	1900
D	685
E	707

BECAUSE WE DO CARE



Aishwarya Consolidates Pvt. Ltd.,

#19, Frist Floor, 10th 'B' Main, 27th Cross,

Third Block Jayanagar, BANGALORE – 560 011, INDIA

Tel: +91-80-2664 1200/1/2 Fax: +91-80-2664 1204

E-mail : aishtek@vsnl.com www.aishwaryaconsolidates.com